

Technical data sheet

Product features



Cooking range gas with static gas oven 2x GN 2/1 - 8x burner

Model	SAP Code	00000324
--------------	-----------------	----------



- Device type: Gas unit
- Power consumption of the zone 1 [kW]: 10
- Power consumption of the zone 2 [kW]: 10
- Power consumption of the zone 3 [kW]: 7
- Power consumption of the zone 4 [kW]: 7
- Power consumption of the zone 5 [kW]: 7
- Power consumption of the zone 6 [kW]: 7
- Ignition: Eternal flame
- Type of internal part of the appliance 1 (eg oven): Gas
- Type of internal part of the appliance 2 (eg oven): Static
- Protection of controls: IPX5
- Material: AISI 304

SAP Code	00000324	Power consumption of the zone 4 [kW]	7
Net Width [mm]	1600	Power consumption of the zone 5 [kW]	7
Net Depth [mm]	900	Power consumption of the zone 6 [kW]	7
Net Height [mm]	900	Power consumption of the zone 7 [kW]	4
Net Weight [kg]	292.00	Power consumption of the zone 8 [kW]	4
Power gas [kW]	73.000	Type of internal part of the appliance 1 (eg oven)	Gas
Type of gas	Natural gas, propane butane	Type of internal part of the appliance 2 (eg oven)	Static
Number of zones	8	Width of internal part [mm]	680
Power consumption of the zone 1 [kW]	10	Depth of internal part [mm]	730
Power consumption of the zone 2 [kW]	10	Height of internal part [mm]	340
Power consumption of the zone 3 [kW]	7		

Technical data sheet

Technical drawing



Cooking range gas with static gas oven 2x GN 2/1 - 8x burner

Model

SAP Code

00000324

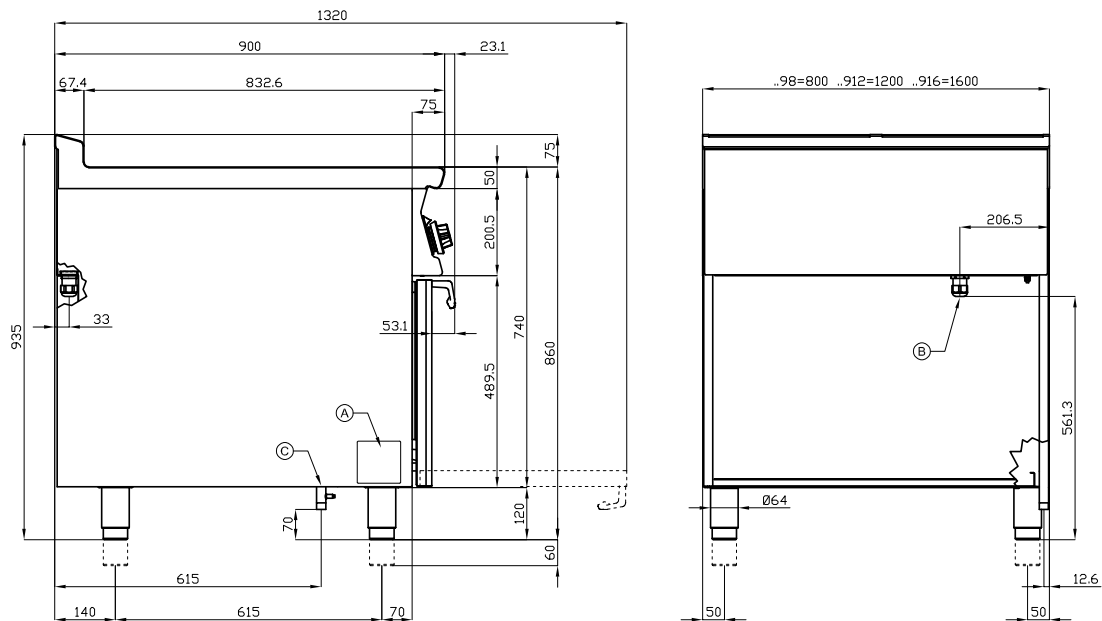

A	Data plate	C	Gas connection	ISO 7-1 3/4" M
---	------------	---	----------------	----------------

Technical data sheet

Product benefits



Cooking range gas with static gas oven 2x GN 2/1 - 8x burner

Model	SAP Code	00000324
--------------	-----------------	----------

1

Massive construction of burners

- high performance and efficiency
- brass burners removable
- eternal flame
- long life
- demountable
 - energy saving (perfect combustion)
 - time saving for food preparation
 - easy maintenance/cleaning

2

Hygienic moldings of the top plate

- absence of sharp corners and edges (potential places where dirt could stick)
- smooth transitions
 - 0

3

Large oven with four rack positions with static cooking

- static baking
- high capacity and variability
- all-stainless design
 - suitable for yeast dishes and desserts
 - long service life
 - easy to clean

4

Degree of protection of the control elements IPX5

- maintenance-free system
- resistance to splash water
- long life
 - savings on service interventions
 - easy cleaning and maintenance of equipment

5

All-stainless steel construction

- the material does not cut
- wear resistance of the material
- long life
 - savings on service interventions
 - easy cleaning and maintenance of equipment

6

Safety element – thermocouple

- safe service for staff
- there is no unnecessary gas leakage
- long life
 - savings on service interventions
 - easier and faster operation

7

Piezoelectric ignition

- instant flame ignition
- there is no unnecessary gas leakage
- long life
 - savings on service interventions
 - easier and faster operation

Technical data sheet

Technical parameters



Cooking range gas with static gas oven 2x GN 2/1 - 8x burner

Model

SAP Code

00000324

1. SAP Code:

00000324

2. Net Width [mm]:

1600

3. Net Depth [mm]:

900

4. Net Height [mm]:

900

5. Net Weight [kg]:

292.00

6. Gross Width [mm]:

1670

7. Gross depth [mm]:

1050

8. Gross Height [mm]:

1120

9. Gross Weight [kg]:

318.00

10. Device type:

Gas unit

11. Construction type of device:

With substructure

12. Power gas [kW]:

73.000

13. Ignition:

Eternal flame

14. Type of gas:

Natural gas, propane butane

15. Protection of controls:

IPX5

16. Exterior color of the device:

Stainless steel

17. Material:

AISI 304

18. Worktop type:

Molded - comfortable cleaning maintenance

19. Worktop material:

AISI 304

20. Worktop Thickness [mm]:

2.00

21. Number of zones:

8

22. Power consumption of the zone 1 [kW]:

10

23. Power consumption of the zone 2 [kW]:

10

24. Power consumption of the zone 3 [kW]:

7

25. Power consumption of the zone 4 [kW]:

7

26. Power consumption of the zone 5 [kW]:

7

27. Power consumption of the zone 6 [kW]:

7

28. Power consumption of the zone 7 [kW]:

4

Technical data sheet

Technical parameters



Cooking range gas with static gas oven 2x GN 2/1 - 8x burner

Model

SAP Code

00000324

29. Power consumption of the zone 8 [kW]:

4

30. Number of power control stages:

6

31. Service accessibility:

From the front by removing the front panel and waste fluid containers

32. Safety thermocouple:

Yes

33. Safety thermostat up to x ° C:

360

34. Adjustable feet:

Yes

35. Number of burners/hot plates:

8

36. Type of gas cooking zones:

Brass burners

37. Burner type:

Brass, detachable

38. Oven Type:

gas static

39. Oven size:

GN 2/1

40. Oven material:

Stainless steel

41. Type of internal part of the appliance 1 (eg oven):

Gas

42. Type of internal part of the appliance 2 (eg oven):

Static

43. Width of internal part [mm]:

680

44. Depth of internal part [mm]:

730

45. Height of internal part [mm]:

340

46. Gasket:

Yes

47. Maximum temperature of the inner chamber [°C]:

300

48. Minimum temperature of the inner chamber [°C]:

150

49. Inner ignition:

Piezoelectric